

Part number:

HYDROMA

HYDRAULICKÉ SYSTÉMY

**HIDROMA
SYSTEMS**

UKŁADY HYDRAULICZNE

HYDROMA

ГИДРАВЛИЧЕСКИЕ СИСТЕМЫ

MHT 42 MPa (420 bar)

HIGH PRESSURE INLINE FILTERS

HOCHDRUCKFILTER

FILTRES EN LIGNE A HAUTE PRESSION

FILTROS DE LINEA DE ALTA PRESION

FILTRI IN LINEA AD ALTA PRESSIONE



GB High pressure inline filters - MHT series -

DESCRIPTION: MHT series filters are normally installed downstream from the pump. The filter elements used (Abs. fibres) provide high efficiency filtration, and positive protection to sensitive components.

TECHNICAL DATA

Max. working pressure: 420bar (42 MPa)
Max. testing pressure: 620 bar (62 MPa)
Min. burst pressure: 1260 bar (126 MPa)
Fatigue test: 0 + 280 bar (0 + 28 MPa)
Head: S.G. cast iron Bowl: forged steel
Working temperature: -25°C + +110°C
By-pass valve: standard Δp 6 bar (600 kPa) \pm 10%
Reverse flow valve: available on request

All tests performed according to the following standards: ISO 2941: Element collapse resistance test - ISO 2942: Production integrity test
ISO 2943: Fluids compatibility - ISO 3723: End load test method - ISO 3724: Flow fatigue resistance method - ISO 3968: Pressure drop versus flow rate - ISO 16889: Multipass test. For further information contact our Technical Dept.

FILTER ELEMENTS

Special paper 10 μ - 25 μ
Inorganic fibres 3 μ - 6 μ - 12 μ - 25 μ Abs
Metal wire mesh 10 μ - 25 μ - 30 μ - 60 μ
Special execution on request.

FILTER ELEMENTS COLLAPSE PRESSURES

Δp 21 bar (2,1 MPa) all types
 Δp 210 bar (21 MPa) 2T - 2C - 2D - 2V - TD - TV - TT - TS

SEALS Standard: Buna-N - On request: FKM - Fluoroelastomer

D Hochdruckfilter - MHT Serie -

BESCHREIBUNG: Die Filter der Serie MHT werden auf der Druckseite der Hochdrucklinie montiert. Die eingesetzten Elemente gestatten einen hohen Abscheidegrad und einen hohen Schutz für die Bauteile des Systems.

TECHNISCHE DATEN

Max. Betriebsdruck: 420bar (42 MPa)
Max. Prüfdruck: 620 bar (62 MPa)
Berstdruck: 1260 bar (126 MPa)
Ermüdungstest: 0 + 280 bar (0 + 28 MPa)
Kopf: Sphäroguss Behälter: Kalifliesspresstahl
Betriebstemperatur: -25°C + +110°C
By-pass Ventil: Standard Δp 6 bar (600 kPa) \pm 10%
Reversierventil: auf Wunsch

Alle Prüfungen werden nach folgenden Normen durchgeführt: ISO 2941: Kollaps u. Berstdruckprüfung - ISO 2942: Feststellung der einwandfreien Fertigungsqualität - ISO 2943: Prüfung der Verträglichkeit des Materials mit den Flüssigkeiten - ISO 3723: Verfahren zur Prüfung der Endscheibenbelastung - ISO 3724: Prüfung zur Bestimmung der Ermüdungseigenschaften - ISO 3968: Bestimmung des Durchflusswiderstandes in Abhängigkeit vom Volumenstrom - ISO 16889: Multipass Test

FILTERELEMENTE

Harzprägniertes Papier 10 μ - 25 μ
Anorganische Fasern 3 μ - 6 μ - 12 μ - 25 μ Abs.
Metallgewebe 10 μ - 25 μ - 30 μ - 60 μ
Sonderausführungen auf Wunsch.

KOLLAPSDRUCK DER FILTERELEMENTE

Δp 21 bar (2,1 MPa) jeder Typ
 Δp 210 bar (21 MPa) FT - FC - FD - FV - RD - RV - RT - MS

DICHTUNGEN Standard: Buna-N - Auf Wunsch: FKM - Fluoroelastomer

F Filtres en ligne haute pression - série MHT -

DESCRIPTION: Les filtres série MHT, sont installés sur lignes à haute pression. Les éléments filtrants utilisés permettent une haute efficacité filtrante et une élevée protection des composants du circuit.

INFORMATIONS TECHNIQUES

Pression max. de service: 420bar (42 MPa)
Pression max. d'essai: 620 bar (62 MPa)
Pression d'éclatement: 1260 bar (126 MPa)
Essai de fatigue: 0 + 280 bar (0 + 28 MPa)
Tête du filtre: Fonte sphéroïdale Bol: Acier
Température de travail: -25°C + +110°C
Valve de By-pass: standard Δp 6 bar (600 kPa) \pm 10%
Valve de non-retour: sur demande

Tous les tests sont réalisés selon les standards suivant: ISO 2941: Test de pression d'écrasement élément filtrant - ISO 2942: Conformité aux détails de production - ISO 2943: Compatibilité media/fluides - ISO 3723: Détermination résistance à la déformation axiale - ISO 3724: Détermination résistance selon variation du débit - ISO 3968: Détermination des pertes de charge selon le débit - ISO 16889: Test Multipass.

ELEMENTS FILTRANTS

Papier special 10 μ - 25 μ
Fibre inorganique 3 μ - 6 μ - 12 μ - 25 μ Abs.
Treillis métalliques 10 μ - 25 μ - 30 μ - 60
Production special sur demande.

PRESSION D'ECRASMENT ELEMENTS FILTRANTS

Δp 21 bar (2,1 MPa) tous les types
 Δp 210 bar (21 MPa) 2T - 2C - 2D - 2V - TD - TV - TT - TS

JOINTS Standard: Buna-N - Sur demande: FKM - Fluoroelastomère

E Filtros de línea de alta presión - serie MHT -

DESCRIPCIÓN: Los filtros de la serie MHT se instalan en la línea de alta presión. Los elementos filtrantes empleados permiten una alta eficiencia filtrante y una elevada protección de los componentes del circuito.

CARACTERÍSTICAS TÉCNICAS

Presión máx de servicio: 420bar (42 MPa)
Presión máx de prueba: 620 bar (62 MPa)
Presión de rotura: 1260 bar (126 MPa)
Ensayo de fatiga: 0 + 280 bar (0 + 28 MPa)
Cabezal: Fundición esferoidal
Cuerpo: Acero extrusionado
Temperatura de servicio: -25°C + +110°C
Válvula by-pass: estándar Δp 6 bar \pm 10%
Válvula anti-retorno: bajo demanda

Todos los ensayos se realizan según las normas siguientes: ISO 2941: Verificación de la presión de aplastamiento del cartucho - ISO 2942: Verificación de conformidad a la fabricación - ISO 2943: Compatibilidad de los materiales con los fluidos - ISO 3723: Prueba de resistencia a la deformación axial - ISO 3724: Prueba de resistencia a la fatiga - ISO 3968: Pérdidas de carga según el caudal - ISO 16889: Prueba multipass

ELEMENTOS FILTRANTES

Papel especial 10 μ - 25 μ
Fibra inorgánica 3 μ - 6 μ - 12 μ - 25 μ Abs.
Tela metálica 10 μ - 25 μ
Ejecución especial bajo pedido.

PRESION DE APLASTAMIENTO DEL CARTUCHO FILTRANTE

Δp 21 bar (2,1 MPa) Todos los modelos
 Δp 210 bar (21 MPa) modelos 2T-2C-2D-2V-TD-TV-TT-TS

JUNTAS Estandar: Buna-N - Bajo demanda: FKM - Fluoroelastomero

I Filtri in linea ad alta pressione - serie MHT -

DESCRIZIONE: I filtri della serie MHT sono installati su linee ad alta pressione. Gli elementi filtranti utilizzati permettono una alta efficienza filtrante ed una elevata protezione nei confronti dei componenti del circuito.

CARATTERISTICHE TECNICHE

Pressione max. di esercizio: 420bar (42 MPa)
Pressione max. di collaudo: 620 bar (62 MPa)
Pressione di scoppio: 1260 bar (126 MPa)
Test di fatica: 0 + 280 bar (0 + 28 MPa)
Testata: Ghisa sferoidale Corpo: Acciaio estruso
Temperatura di lavoro: -25°C + +110°C
Valvola di By-pass: standard Δp 6 bar (600 kPa) \pm 10%
Valvola di non ritorno: disponibile su richiesta

Tutti i test sono stati eseguiti secondo le seguenti norme: ISO 2941: Test verifica pressione collasso cartuccia - ISO 2942: Test verifica di conformità di fabbricazione - ISO 2943: Test verifica compatibilità materiali con fluidi - ISO 3723: Test per resistenza alla deformazione assiale - ISO 3724: Test determinazione resistenza alla fatica - ISO 3968: Test perdite di carico in funzione della portata - ISO 16889: Prova Multipass

ELEMENTI FILTRANTI

Carta speciale 10 μ - 25 μ
Fibra inorganica 3 μ - 6 μ - 12 μ - 25 μ Abs
Tela metallica 10 μ - 25 μ - 30 μ - 60 μ
Esecuzioni speciali su richiesta.

PRESSIONE COLLASSO CARTUCCE FILTRANTI

Δp 21 bar (2,1 MPa) tutti i tipi
 Δp 210 bar (21 MPa) 2T - 2C - 2D - 2V - TD - TV - TT - TS

GUARNIZIONI Standard: Buna-N - A richiesta: FKM - Fluoroelastomero

**INSTALLATION DETAILS
EINBAUSYSTEME**

**INSTALLATION
SISTEMA DI MONTAGGIO**

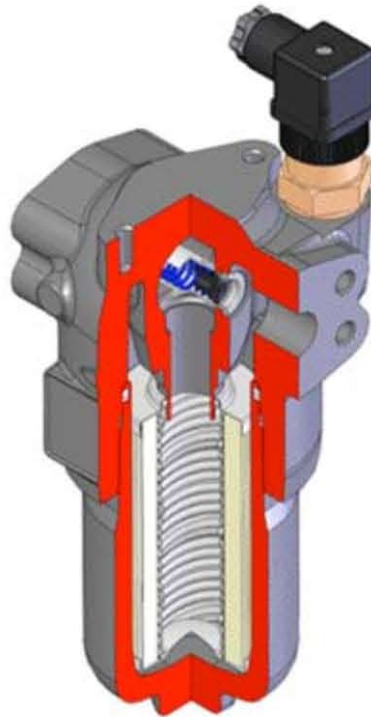

**CLOGGING INDICATORS
VERSCHMUTZUNGSANZEIGEN**

**INDICATEUR DE COLMATAGE
INDICATORI DI INTASAMENTO**

Series Série Serie	Setting Tarierung Réglage Taratura	Type Typ Tipo
5E - 5F	5 bar (500 kPa) 8 bar (800 kPa)	Visual differential Optischer Differenzdruckanzeiger Diffrénel visuel Differenziale visivo
6E - 6F	5 bar (500 kPa) 8 bar (800 kPa)	Electrical differential - IP65 - Connection plug DIN43650 Elektrisch Diff. - IP65 - Steck-Verbindung nach DIN43650 Diffrénel électrique - IP65 - Raccordement DIN43650 Differenziale elettrico - IP65 - Connessione DIN43650
7E - 7F	5 bar (500 kPa) 8 bar (800 kPa)	Indicator 6E with LED (24V) Verschmutzungsanzeige 6E mit LED (24V) Indicateur 6E avec LED (24V) Indicatore 6E con LED (24V)
7F	8 bar (800 kPa)	Indicator 6F with LED (24V) Verschmutzungsanzeige 6F mit LED (24V) Indicateur 6F avec LED (24V) Indicatore 6F con LED (24V)
T2 - T3	5 bar (500 kPa) 8 bar (800 kPa)	Electrical with thermostat 30°C IP65 - Connection plug DIN43650 Elektrisch mit Thermostat 30°C IP65 - Steck-Verbindung nach DIN43650 Electrique avec thermostat 30°C IP65 - Raccordement DIN43650 Elettrico con termostato 30°C IP65 - Connessione DIN43650
72 - 73	5 bar (500 kPa) 8 bar (800 kPa)	On request only See page 15 Nur auf Wunsch Sehen Sie Seite 15 Seulement sur demande Voir la page 15 Solo su richiesta Vedi pagina 15

**HOW TO ORDER THE COMPLETE FILTER
BESTELLBEZEICHNUNG FÜR KOMPLETTFILTER
DETERMINATION D'UN FILTRE
ORDINAZIONE DEL FILTRO COMPLETO**

**HOW TO ORDER REPLACEMENT CARTRIDGES
BESTELLBEZEICHNUNG FÜR FILTERELEMENTE
CODIFICATION CARTOUCHE DE RECHANGE
ORDINAZIONE DELLA CARTUCCIA DI RICAMBIO**

MHT	Type - Typ - Type - Tipo				Type - Typ - Type - Tipo	CCH
		151	301	801		
		152	302	802		
		153	-	803		
		-	-	804		
	Filter media - Filtermaterial Finesse media - Materiale filtrante				Filter media - Filtermaterial Finesse media - Materiale filtrante	
	FT = 3µ Inorganic fibres Anorganische Fasern	FT	FT	FT	FT = 3µ Inorganic fibres Anorganische Fasern	
	FC = 6µ Fibre inorganique Fibre inorganiche	FC	FC	FC	FC = 6µ Fibre inorganique Fibre inorganiche	
	FD = 12µ β>200	FD	FD	FD	FD = 12µ β>200	
	FV = 25µ	FV	FV	FV	FV = 25µ	
	CD = 10µ Papier Papier	CD	CD	CD	CD = 10µ Papier Papier	
	CV = 25µ Papier Carta	CV	CV	CV	CV = 25µ Papier Carta	
	RD = 10µ Steel wire mesh Metalgewebe	RD	RD	RD	RD = 10µ Steel wire mesh Metalgewebe	
	MV = 25µ Trellis metal Tela metalica	MV	MV	MV	MV = 25µ Trellis metal Tela metalica	
	2T = 3µ Inorganic fibres Anorganische Fasern	2T	2T	2T	2T = 3µ Inorganic fibres Anorganische Fasern	
	2C = 6µ Fibre inorganique Fibre inorganiche	2C	2C	2C	2C = 6µ Fibre inorganique Fibre inorganiche	
	2D = 12µ β>200 - Δp = 210 bar (21.000 kPa)	2D	2D	2D	2D = 12µ β>200 - Δp = 210 bar (21.000 kPa)	
	2V = 25µ	2V	2V	2V	2V = 25µ	
	TD = 10µ Steel wire mesh Metalgewebe	TD	TD	TD	TD = 10µ Steel wire mesh Metalgewebe	
	TV = 25µ Trellis metal Tela metalica	TV	TV	TV	TV = 25µ Trellis metal Tela metalica	
	TV = 25µ Δp = 210 bar (21 MPa)	TV	TV	TV	TV = 25µ Δp = 210 bar (21 MPa)	
	Seals - Dichtungen - Joints - Guarnizioni				Seals - Dichtungen - Joints - Guarnizioni	
	1 = NBR - Nitrile - Buna-N	1	1	1	1 = NBR - Nitrile - Buna-N	
	2 = FKM - Fluoroelastomer	2	2	2	2 = FKM - Fluoroelastomer	
	Bypass type - Type de by-pass Bypass Typ - Tipo di bypass					
	S = Without - Ohne - Sans - Senza	S	S	S		
	C = With - Mit - Avec - Con 6 bar (600 kPa)	C	C	C		
	P = With - Mit - Avec - Con 6 bar (600 kPa) + option R	-	P	P		
	R = Rev. flow valve - Reversieren - Valse à 2 sens de déb. - Valv. flusso inv.	-	R	R		
	Ports - Anschlussart - Raccordements Tipo Attacchi					
	B = BSP	B	B	B		
	N = NPT (N3 not avail. - nicht lieferbar - pas dispon. - non dispon.)	N	N	N		
	S = SAE	S	S	S		
	F = SAE 3000 psi Flange - Flansch - Bride - Flangia	-	F	F		
	H = SAE 6000 psi Flange - Flansch - Bride - Flangia	-	H	H		
	Port size - Anschlüsse Raccordements - Grandezza attacchi					
	3 = 1/2"	3	-	-		
	4 = 3/4"	4	4	-		
	5 = 1" (*)	-	5	5		
	6 = 1 1/4"	-	-	6		
	7 = 1 1/2" (H7-E7 not avail. - nicht lieferbar - pas dispon. - non dispon.)	-	-	7		
	Indicators - Anzeiger - Indicateurs - Indicatori					
	03 = Predisposition - Mit Bohrungen - Predisposition - Predisposizione	03	03	03		
	5E = Visual diff. - Opt. Diff. - Diff. visuel - Diff. visivo 5 bar (500 kPa)	5E	5E	5E		
	5F = Visual diff. - Opt. Diff. - Diff. visuel - Diff. visivo 8 bar (800 kPa)	5F	5F	5F		
	6E = Elec. diff. - Elek. Diff. - Diff. elec. - Diff. Electr. 5 bar (500 kPa)	6E	6E	6E		
	6F = Elec. diff. - Elek. Diff. - Diff. elec. - Diff. Electr. 8 bar (800 kPa)	6F	6F	6F		
	7E = 6E with LED - 6E mit LED - 6E avec LED - 6E con LED	7E	7E	7E		
	7F = 6F with LED - 6F mit LED - 6F avec LED - 6F con LED	7F	7F	7F		
	T2 = Elec. - Elek. - Elec. - Electr. 5 bar (500 kPa) with thermostat 30°C	T2	T2	T2		
	T3 = Elec. - Elek. - Elec. - Electr. 8 bar (800 kPa) with thermostat 30°C	T3	T3	T3		
	Accessories - Zubehör - Accessoires - Accessori					
XX	XX = Not avail. - Nicht lieferbar - Pas prévus - Non prev.	XX	XX	XX		

On request only - Nur auf Wunsch
Seulement sur demande - Solo su richiesta

(*) = F5 only for - nur für - seul pour - solo per MHT30+
H5 > MHT30+ not avail. - nicht lieferbar - pas dispon. - non dispon.
F5/H5 > MHT80+ not avail. - nicht lieferbar - pas dispon. - non dispon.

N.B. Indicator 72 - 73
On request only - Nur auf Wunsch
Seulement sur demande - Solo su richiesta

**DIMENSIONAL LAYOUT
TECHNISCHE MASSDATEN**

(mm)

**ENCOMBREMENT
DATI TECNICI DIMENSIONALI**

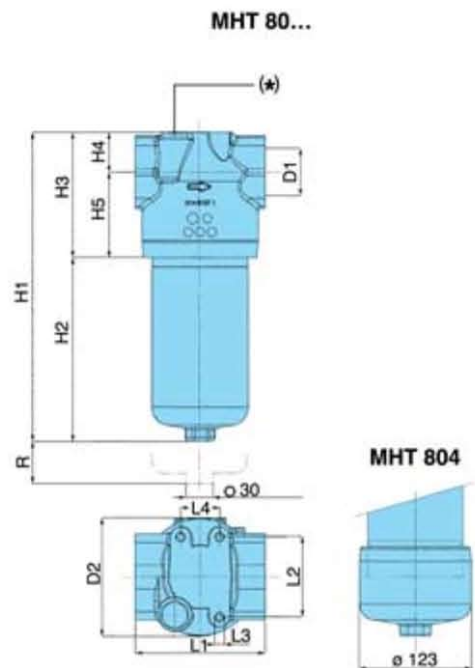
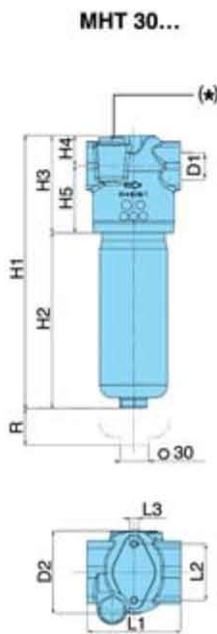
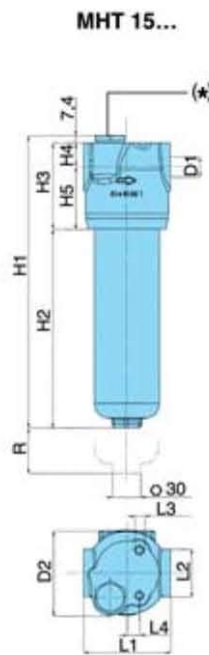

(*) Indicator port - Anschluß Anzeige - Raccordement pour indicateur - Sede per indicatore

Type Typ Type Tipo	D1	D2	H1	H2	H3	H4	H5	L1	L2	L3	L4	R	Peso kg
MHT 151	1/2" - 3/4"	86	166	79	87	24	63	88	46	M8 5/16" 18 UNC	12,5	100	4,4
MHT 152	1/2" - 3/4"	86	196	109	87	24	63	88	46		12,5	100	4,6
MHT 153	1/2" - 3/4"	86	296	209	87	24	63	88	46		12,5	100	5,2
MHT 301	3/4" - 1"	94	226	116	112	35	77	108	65		=	100	6,6
MHT 302	3/4" - 1"	94	317	207	112	35	77	108	65	=	100	8,2	
MHT 801	1" - 1 1/4" - 1 1/2"	128	245	107	138	44	94	143	88	M10 7/16" 14 UNC	43	100	11,0
MHT 802	1" - 1 1/4" - 1 1/2"	128	337	199	138	44	94	143	88		43	100	13,9
MHT 803	1" - 1 1/4" - 1 1/2"	128	457	319	138	44	94	143	88		43	100	17,2
MHT 804	1" - 1 1/4" - 1 1/2"	128	558	420	138	44	94	143	88		43	100	22,0

Flange mounting bolt dimensions (mm)
Bohrungsabmessungen des Flanschanschlusses (mm)

Type Typ Type Tipo	Code Code Code Codice	D1	Max. pressure Max. Druck Pression max. Pressione max.	L5	L6	D3	T*
MHT 30	H4	3/4"	420 bar	50,8	23,8	M10	14
	E4	3/4"	420 bar	50,8	23,8	3/8" 16 UNC	14
	F5	1"	210 bar	52,4	26,2	M10	14
	D5	1"	210 bar	52,4	26,2	3/8" 16 UNC	14
MHT 80	H6	1 1/4"	420 bar	66,7	31,8	M14	19
	E6	1 1/4"	420 bar	66,7	31,8	1/2" 13 UNC	19
	F6	1 1/4"	210 bar	58,72	30,18	M10	19
	D6	1 1/4"	210 bar	58,72	30,18	7/16" 14 UNC	19
	F7	1 1/2"	210 bar	70,0	35,7	M12	19
	D7	1 1/2"	210 bar	70,0	35,7	1/2" 13 UNC	19

Dimensions foreure pour contre-bride (mm)
Dimensioni foratura per controflange (mm)

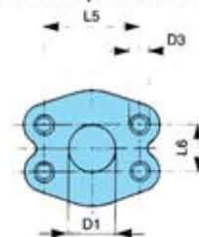

* T =
min. thread depth
min. Gewindetiefe
min. Profondeur filetage
min. profondità di filettatura

**FLOW RATES
NENNVOLUMENSTROM**

(L/min)

**DEBITS
PORTATE**

Type Typ Type Tipo	Filters elements Filterelemente Elements filtrants Elementi filtranti	Δ p		
		0,5 bar	1 bar	1,5 bar
		MHT 151 (*)	FT	11
FC	14		26	40
FD	19		38	57
FV	31		60	85
CD	45		75	90
CV	75		90	90
RD	70		90	90
MV	80		90	90
TD	68		90	90
TV	78		90	90
2T	9		19	25
2C	12		23	35
2D	16	33	52	
2V	27	50	77	
MHT 152 (*)	FT	15	30	45
	FC	18	35	50
	FD	25	50	75
	FV	40	68	90
	CD	50	80	90
	CV	80	90	90
	RD	75	90	90
	MV	85	90	90
	TD	73	90	90
	TV	83	90	90
	2T	13	26	41
	2C	15	30	47
2D	22	46	70	
2V	35	60	85	
MHT 153 (*)	FT	22	35	50
	FC	24	41	56
	FD	35	55	85
	FV	55	83	90
	CD	72	90	90
	CV	85	90	90
	RD	80	90	90
	MV	90	90	90
	TD	78	90	90
	TV	90	90	90
	2T	20	33	48
	2C	22	38	52
2D	31	50	81	
2V	50	78	90	

Kinematic viscosity 30 cSt
Density < 0,9 Kg/dm³

Kinematische Viskosität 30 cSt
Dichte < 0,9 Kg/dm³

Viscosité 30 cSt
Densité < 0,9 Kg/dm³

Viscosità cinematica 30 cSt
Densità < 0,9 Kg/dm³

Type Typ Type Tipo	Filters elements Filterelemente Elements filtrants Elementi filtranti	Δ p		
		0,5 bar	1 bar	1,5 bar
		MHT 301 (*)	FT	25
FC	27		62	81
FD	39		73	95
FV	62		110	150
CD	80		130	150
CV	110		150	150
RD	100		150	150
MV	120		150	150
TD	97		150	150
TV	117		150	150
2T	23		51	67
2C	24		58	76
2D	36	67	90	
2V	57	100	145	
MHT 302 (*)	FT	34	63	79
	FC	38	73	90
	FD	50	84	104
	FV	75	119	150
	CD	122	150	150
	CV	135	150	150
	RD	130	150	150
	MV	148	150	150
	TD	127	150	150
	TV	144	150	150
	2T	30	60	74
	2C	34	68	86
2D	47	78	100	
2V	70	109	150	
MHT 801 (*)	FT	39	73	124
	FC	46	91	142
	FD	79	154	193
	FV	105	194	240
	CD	159	240	240
	CV	219	240	240
	RD	178	240	240
	MV	186	240	240
	TD	150	240	240
	TV	155	240	240
	2T	27	48	74
	2C	36	62	87
2D	50	98	131	
2V	73	130	184	

Type Typ Type Tipo	Filters elements Filterelemente Elements filtrants Elementi filtranti	Δ p		
		0,5 bar	1 bar	1,5 bar
		MHT 802 (*)	FT	93
FC	128		218	281
FD	163		286	300
FV	201		300	300
CD	239		300	300
CV	279		300	300
RD	261		300	300
MV	291		300	300
TD	217		300	300
TV	242		152	300
2T	71		152	190
2C	125		167	216
2D	125	230	280	
2V	153	280	300	
MHT 803 (*)	FT	131	270	340
	FC	140	287	350
	FD	170	325	420
	FV	225	380	420
	CD	290	420	420
	CV	320	420	420
	RD	311	420	420
	MV	335	420	420
	TD	260	420	420
	TV	280	420	420
	2T	109	225	283
	2C	116	239	291
2D	141	270	408	
2V	187	316	420	
MHT 804 (*)	FT	173	351	420
	FC	188	363	420
	FD	237	410	420
	FV	312	420	420
	CD	330	420	420
	CV	340	420	420
	RD	331	420	420
	MV	355	420	420
	TD	277	420	420
	TV	295	420	420
	2T	144	292	310
	2C	156	302	362
2D	197	341	420	
2V	260	390	420	

(*) Port 3/4" - Anschluß 3/4" - Raccordement 3/4" - Attacco 3/4"
 (**) Port 1" - Anschluß 1" - Raccordement 1" - Attacco 31"
 (***) Port 1 1/2" - Anschluß 1 1/2" - Raccordement 31 1/2" - Attacco 1 1/2"

DIRT HOLDING CAPACITY
SCHMUTZANSAMMLUNGSKAPAZITÄT
CAPACITE D'ACCUMULATION
CAPACITA' D'ACCUMULO

(g)ACFTD
 $\Delta p = 5 \text{ bar}$

FILTER AREA (cm²)
FILTERFLÄCHE (cm²)
SURFACE FILTRANTE (cm²)
AREA FILTRANTE (cm²)

Type Typ Tipo	Filter element Filterelemente Elements filtrants Elementi filtranti									
	FT	2T	FC	2C	FD	2D	FV	2V	CD	CV
CCH 151	1,8	1,8	2,3	2,3	2,6	2,6	3,8	3,8	2,1	2,3
CCH 152	2,6	2,6	3,3	3,3	3,7	3,7	5,4	5,4	3,0	3,3
CCH 153	4,8	4,8	6,3	6,3	6,8	6,8	10,0	10,0	5,6	6,0
CCH 301	5,0	5,0	6,6	6,6	7,2	7,2	10,6	10,6	5,4	5,8
CCH 302	9,5	9,5	12,3	12,3	13,6	13,6	19,0	19,0	10,2	11,0
CCH 801	10,4	7,6	13,5	9,9	15,0	11,0	22,0	16,0	12,0	17,9
CCH 802	19,2	14,0	24,0	18,0	27,0	20,0	40,0	29,0	22,0	23,6
CCH 803	25,0	22,0	33,0	28,0	37,0	32,0	54,0	46,0	35,0	37,0
CCH 804	34,0	29,0	43,0	37,0	49,0	42,0	70,0	61,0	46,0	49,0

Type Typ Tipo	Filters elements Filterelemente Elements filtrants Superficie filtrante			
	RD	TD	MV	TV
CCH 151	300	300	300	300
CCH 152	430	430	430	430
CCH 153	805	805	805	805
CCH 301	770	770	770	770
CCH 302	1455	1455	1455	1455
CCH 801	1710	1430	1710	1430
CCH 802	3160	2210	3160	2210
CCH 803	5020	3560	5020	3560
CCH 804	6580	4700	6580	4700

FILTRATION EFFICIENCY
FILTERLEISTUNG
FINESSE FILTRANT
EFFICENZA FILTRANTE
(MULTIPASS TEST ISO 4572)

Filter elements Filtermaterial Elements filtrante Elementi filtranti	Δp (bar)	β_x Ratio β_x Verhältnis		Rapport β_x Rapporto β_x	
		83	86	812	825
FT = 3 μ	5	106	246	963	>5000
FC = 6 μ	5	36	100	294	>5000
FD = 12 μ	5	6	18	144	580
FV = 25 μ	5	1	1,5	5,2	126
CD = 10 μ	5	1	1,3	2,1	5
CV = 25 μ	5	1	1	1,3	2