

Part number:

HYDROMA

HYDRAULICKÉ SYSTÉMY

**HIDROMA
SISTEMS**

UKŁADY HYDRAULICZNE

HYDROMA

ГИДРАВЛИЧЕСКИЕ СИСТЕМЫ

MONOBLOCK

TYPE EMS103/...38...

MONOBLOCCO

TIPO EMS103/...38...

Monoblock with side and rear ports A-B = 3/8" G, P-T = 1/2" G
Series connection. With/without pressure relief valve. (RV)
Monoblocco con utilizzi A-B posteriori e laterali da 3/8" G, P-T da 1/2" G
Versione in serie, con/senza valvola lim. di pressione.

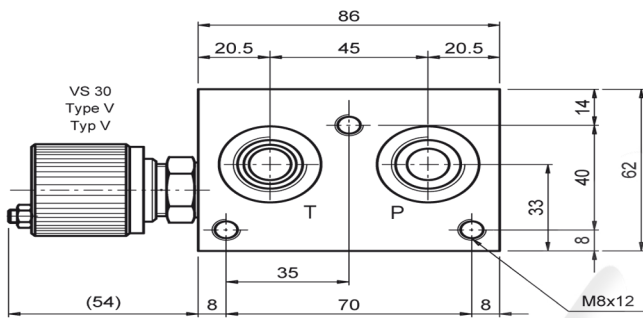

N° Elem.	H	K	Kg
2	160	144	4.8
3	210	194	6.2
4	260	244	7.6

Hydraulic symbol
Series connection
Schema idraulico
in serie

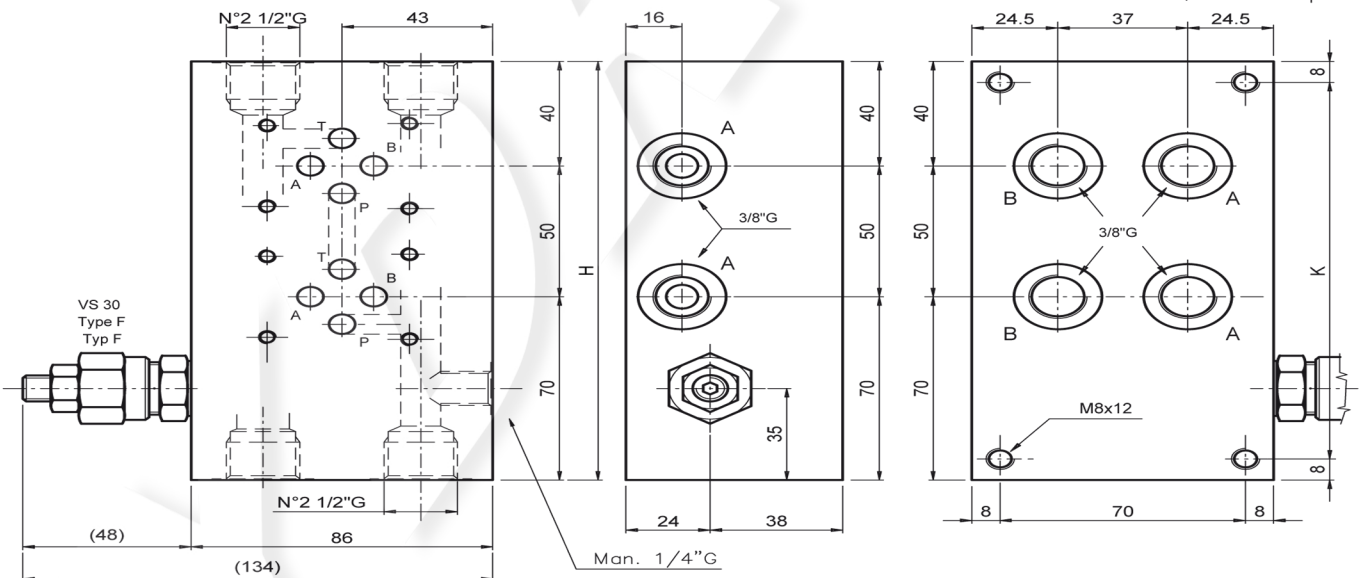
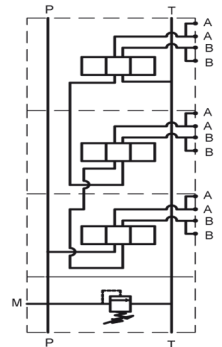

Ordering code:

Esempio di ordinazione: **EM** **S** **10** **3** / ***** **38** ***** ***** *****

EUROFLUID
monoblock = M
monoblocco =
for series / serie =

rear / side ports = 10
versione poster./later. =

CETOP 3

N. of elements = 2-3-4
N° stazioni

3/8" G = 38

Setting / regolazione

F = by key / a chiave
V = handwheel/ Volantino
P = plastic knob/ Pomolo

Spring type / tipo molla

0 = 5-50 bar
1 = 30-100 bar
2 = 50-210 bar
3 = 100-350 bar

Z = prearranged for RV
= con sede per VLP

T = with plugged RV seat
= con sede tappata per VLP

X = with RV included
= con VLP inclusa

NOTES : See page 50 for technical characteristics of RV
NOTA: Per informazioni tecniche relative alla VLP vedere pag 50