

Part number:

HYDROMA

HYDRAULICKÉ SYSTÉMY

**HIDROMA
SYSTEMS**

UKŁADY HYDRAULICZNE

HYDROMA

ГИДРАВЛИЧЕСКИЕ СИСТЕМЫ

NEW MODULAR ELIT SERIES

C A G M M 3EL 160 M 2 a

2EL : Elit Series IE2 High Efficiency motors

3EL : Elit Series IE3 Premium Efficiency motors

New design modular Elit Series offer a high performance with unique and flexible options for variable application areas. Different than standard series, Elit series motors have removable feet design for 132-200 frame size. The feet mounting system offers great flexibility and it is very simple allowing change on the mounting configuration without requiring any machining or modification on the motor feet. In addition to this only for 132 aluminium frame motor detachable flange and plastic fan cover will be available.

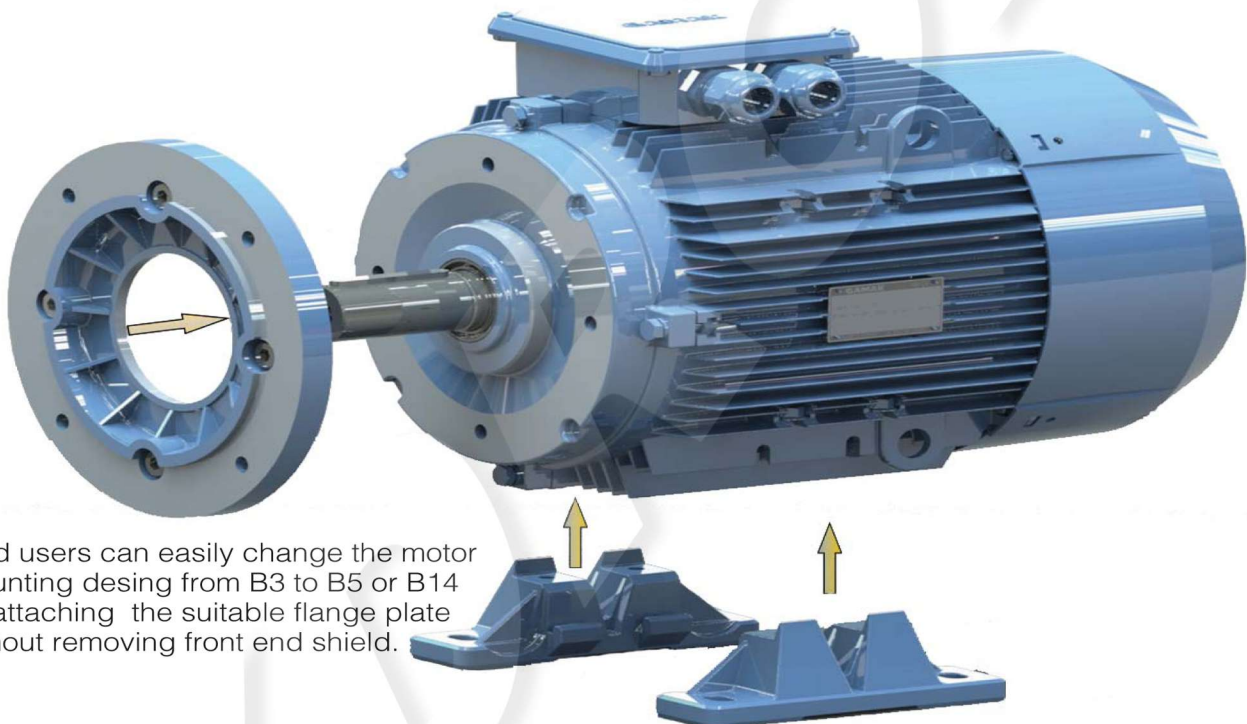

* End users can easily change the motor mounting desing from B3 to B5 or B14 by attaching the suitable flange plate without removing front end shield.

*Due to the removable feet design motor terminal box can also be rotated at 90 degrees allowing motor leads to be connected on 3 side of the motor.

Frames, end-shields and flanges

The following table shows the materials of motor frames, endshields and flanges :

Frame Size	Frame	End Shields	Flanges			Removable Feet		Attachable Flange	
			B5	B14/Small	B14/Large	Al. Housing	Cast Iron Housing	Al. Housing	Cast Iron Housing
132	Aluminium or Cast Iron	Aluminium or Cast Iron	Aluminium or Cast Iron	Aluminium	Cast Iron	√	-	√	-
160				Cast Iron				-	
180				-	-			-	
200				-	-			-	

In aluminium Elit Series removable feet are cast separately from motor frames but in cast iron elit series feet are cast integrally with frames. Detachable flanges are only available for 132 frame size.

ELIT SERIES - RATINGS AND PERFORMANCE

PREMIUM EFFICIENCY MOTORS

IE3 3-phase, 400 V, 50 Hz
 Duty type : S1 (continuous)
 Degree of protection : IP 55
 Insulation class : F (155°C)
 Temp. Rise : Class B (80K)

ALUMINIUM HOUSING

Rated output	Type	Full-load data							Starting data				Breakdown torque ratio M_K / M_N	Moment of inertia J	Weight approx. B3 kg
		Speed	Current	Torque	Power Factor	Efficiency η %			Locked-rotor current ratio I_A / I_N		Locked-rotor torque ratio M_A / M_N				
		n	I_N	M_N	Cos ϕ	IEC 60034-2-1:2007			D.O.L.	Y/ Δ	D.O.L.	Y/ Δ			
kW		min ⁻¹	A	Nm		At 4/4	At 3/4	At 1/2	D.O.L.	Y/ Δ	D.O.L.	Y/ Δ	kgm ²	kg	

2 pole, 3000 min⁻¹

5.5	AGM3EL 132 S 2	2925	9.7	17.9	0.89	89.2	89.0	87.4	7.2	2.4	2.1	0.7	2.8	0.0150	41
7.5	AGM3EL 132 M 2	2930	12.9	24.5	0.93	90.1	90.1	89.5	7.8	2.6	2.0	0.7	2.9	0.0210	66
11.00	AGM3EL 160 M 2a	2955	19.0	35.7	0.91	91.2	91.2	90.4	6.6	2.2	1.8	0.6	2.6	0.0310	90
15.00	AGM3EL 160 M 2b	2955	25.7	48.6	0.92	91.9	91.8	91.6	7.9	2.6	2.2	0.7	2.9	0.0410	105
18.50	AGM3EL 160 L 2	2960	31.4	59.9	0.92	92.4	92.5	92.0	8.1	2.7	2.2	0.7	3.1	0.0490	122
22.00	AGM3EL 180 M 2	2960	36.9	71.1	0.93	92.7	92.6	92.2	8.9	3.0	2.9	1.0	3.4	0.0910	157
30	AGM3EL 200 L 2a	2980	52	96	0.89	93.3	93.3	92.8	8.5	2.7	2.8	0.9	3.5	0.15	142
37	AGM3EL 200 L 2b	2980	63	119	0.90	93.7	93.7	93.1	8.3	2.7	2.8	0.9	3.1	0.17	172

4 pole, 1500 min⁻¹

5.5	AGM3EL 132 S 4	1470	11	35.7	0.81	89.6	89.6	88.8	7.0	2.3	2.7	0.9	3.3	0.026	36
7.5	AGM3EL 132 M 4	1470	15	48.7	0.78	90.4	90.5	89.6	7.5	2.5	3.0	1.0	3.6	0.032	41
11.00	AGM3EL 160 M 4	1470	21.1	71.5	0.82	91.4	91.3	91.0	6.1	2.0	1.9	0.6	2.6	0.0760	92
15.00	AGM3EL 160 L 4	1475	28.5	97.2	0.82	92.1	92.0	91.8	6.7	2.2	2.0	0.7	2.9	0.1020	128
18.50	AGM3EL 180 M 4	1475	33.7	119.8	0.85	92.6	92.6	91.6	7.9	2.6	2.5	0.8	2.8	0.1770	160
22.00	AGM3EL 180 L 4	1475	39.4	142.6	0.87	93.0	92.8	92.0	7.5	2.5	2.4	0.8	2.8	0.1920	176
30.00	AGM3EL 200 L 4	1475	52.8	194.1	0.88	93.6	93.5	93.3	8.2	2.7	2.4	0.8	3.0	0.2640	225

6 pole, 1000 min⁻¹

3.00	AGM3EL 132 S 6	970	7.3	29.5	0.69	85.8	85.6	85.2	5.4	1.8	2.1	0.7	2.9	0.0230	39
4.00	AGM3EL 132 M 6a	975	10.2	39.4	0.65	86.8	86.7	86.4	5.6	1.9	2.5	0.8	3.1	0.0280	47
5.50	AGM3EL 132 M 6b	975	13.7	54.1	0.66	88.0	87.8	87.5	5.9	2.0	2.6	0.9	3.3	0.0360	55
7.50	AGM3EL 160 M 6	970	16.2	73.5	0.75	89.1	89.0	88.1	6.7	2.2	2.6	0.9	3.4	0.0910	96
11.00	AGM3EL 160 L 6	975	22.7	107.9	0.78	90.3	90.3	89.0	7.1	2.4	2.5	0.8	3.4	0.1300	122
15.00	AGM3EL 180 L 6	975	28.7	146.8	0.83	91.2	91.2	90.8	8.0	2.7	2.4	0.8	3.2	0.2160	162
18.50	AGM3EL 200 L 6a	980	36.8	180.7	0.79	91.7	91.6	91.3	7.9	2.6	2.5	0.8	3.3	0.2890	188
22.00	AGM3EL 200 L 6b	980	42.2	214.9	0.82	92.2	92.0	91.7	7.4	2.5	2.9	1.0	2.9	0.3440	215

Efficiencies are calculated according to indirect method where the additional load losses are determined from exact measurements at different load points.
 (IEC 60034-2-1 : 2014)

ELIT SERIES - RATINGS AND PERFORMANCE

PREMIUM EFFICIENCY MOTORS

IE3 3-phase, 400 V, 50 Hz
 Duty type : S1 (continuous)
 Degree of protection : IP 55
 Insulation class : F (155°C)
 Temp. Rise : Class B (80K)

ALUMINIUM HOUSING

Rated output	Type	Full-load data							Starting data				Breakdown torque ratio M_K / M_N	Moment of inertia J	Weight approx. B3 kg	
		Speed	Current	Torque	Power Factor	Efficiency η %			Locked-rotor current ratio I_A / I_N		Locked-rotor torque ratio M_A / M_N					
		n min ⁻¹	I _N A	M _N Nm	Cos ϕ	IEC 60034-2-1:2007			D.O.L.	Y/ Δ	D.O.L.	Y/ Δ				
kW						At 4/4	At 3/4	At 1/2							kgm ²	kg

2 pole, 3000 min⁻¹

5.5	GM3EL 132 S 2	2925	9.7	17.9	0.89	89.2	89.0	87.4	7.2	2.4	2.1	0.7	2.8	0.0150	66.5
7.5	GM3EL 132 M 2	2930	12.9	24.5	0.93	90.1	90.1	89.5	7.8	2.6	2.0	0.7	2.9	0.0210	80.4
11.00	GM3EL 160 M 2a	2955	19.0	35.7	0.91	91.2	91.2	90.4	6.6	2.2	1.8	0.6	2.6	0.0310	113
15.00	GM3EL 160 M 2b	2955	25.7	48.6	0.92	91.9	91.8	91.6	7.9	2.6	2.2	0.7	2.9	0.0410	128
18.50	GM3EL 160 L 2	2960	31.4	59.9	0.92	92.4	92.5	92.0	8.1	2.7	2.2	0.7	3.1	0.0490	145
22.00	GM3EL 180 M 2	2960	36.9	71.1	0.93	92.7	92.6	92.2	8.9	3.0	2.9	1.0	3.4	0.0910	193
30	GM3EL 200 L 2a	2980	52	96	0.89	93.3	93.3	92.8	8.5	2.7	2.8	0.9	3.5	0.15	190
37	GM3EL 200 L 2b	2980	63	119	0.90	93.7	93.7	93.1	8.3	2.7	2.8	0.9	3.1	0.17	220

4 pole, 1500 min⁻¹

5.5	GM3EL 132 S 4	1470	11	35.7	0.81	89.6	89.6	88.8	7.0	2.3	2.7	0.9	3.3	0.026	48
7.5	GM3EL 132 M 4	1470	15.4	48.7	0.78	90.4	90.5	89.6	7.5	2.5	3.0	1.0	3.6	0.032	56
11.00	GM3EL 160 M 4	1470	21.1	71.5	0.82	91.4	91.3	91.0	6.1	2.0	1.9	0.6	2.6	0.0760	124
15.00	GM3EL 160 L 4	1475	28.5	97.2	0.82	92.1	92.0	91.8	6.7	2.2	2.0	0.7	2.9	0.1020	151
18.50	GM3EL 180 M 4	1475	33.7	119.8	0.85	92.6	92.6	91.6	7.9	2.6	2.5	0.8	2.8	0.1770	194
22.00	GM3EL 180 L 4	1475	39.4	142.6	0.87	93.0	92.8	92.0	7.5	2.5	2.4	0.8	2.8	0.1920	215
30.00	GM3EL 200 L 4	1475	52.8	194.1	0.88	93.6	93.5	93.3	8.2	2.7	2.4	0.8	3.0	0.2640	273

6 pole, 1000 min⁻¹

3.00	GM3EL 132 S 6	970	7.3	29.5	0.69	85.8	85.6	85.2	5.4	1.8	2.1	0.7	2.9	0.0230	53
4.00	GM3EL 132 M 6a	975	10.2	39.4	0.65	86.8	86.7	86.4	5.6	1.9	2.5	0.8	3.1	0.0280	62
5.50	GM3EL 132 M 6b	975	13.7	54.1	0.66	88.0	87.8	87.5	5.9	2.0	2.6	0.9	3.3	0.0360	71
7.50	GM3EL 160 M 6	970	16.2	73.5	0.75	89.1	89.0	88.1	6.7	2.2	2.6	0.9	3.4	0.0910	119
11.00	GM3EL 160 L 6	975	22.7	107.9	0.78	90.3	90.3	89.0	7.1	2.4	2.5	0.8	3.4	0.1300	145
15.00	GM3EL 180 L 6	975	28.7	146.8	0.83	91.2	91.2	90.8	8.0	2.7	2.4	0.8	3.2	0.2160	201
18.50	GM3EL 200 L 6a	980	36.8	180.7	0.79	91.7	91.6	91.3	7.9	2.6	2.5	0.8	3.3	0.2890	236
22.00	GM3EL 200 L 6b	980	42.2	214.9	0.82	92.2	92.0	91.7	7.4	2.5	2.9	1.0	2.9	0.3440	262

Efficiencies are calculated according to indirect method where the additional load losses are determined from exact measurements at different load points.
 (IEC 60034-2-1 : 2014)

ELIT SERIES - RATINGS AND PERFORMANCE

IE2 3-phase, 400 V, 50 Hz
 Duty type : S1 (continuous)
 Degree of protection : IP 55
 Insulation class : F (155°C)
 Temp. Rise : Class B (80K)

ALUMINIUM HOUSING

Rated output	Type	Full-load data							Starting data				Breakdown torque ratio M_K / M_N	Moment of inertia J	Weight approx. B3
		Speed	Current	Torque	Power Factor	Efficiency η %			Locked-rotor current ratio I_A / I_N		Locked-rotor torque ratio M_A / M_N				
		n	I_N	M_N	Cos ϕ	IEC 60034-2-1:2007			D.O.L.	Y/ Δ	D.O.L.	Y/ Δ			
kW		min ⁻¹	A	Nm		At 4/4	At 3/4	At 1/2						kgm ²	kg

2 pole, 3000 min⁻¹

5.5	AGM2EL 132 S 2	2905	9.8	18.1	0.92	87.3	87.3	86.5	6.2	2.1	1.9	0.6	2.5	0.0130	31
7.5	AGM2EL 132 M 2	2910	13.6	24.6	0.90	88.5	88.5	87.9	7.2	2.3	3.0	1.0	3.4	0.014	50
11.00	AGM2EL 160 M 2a	2945	19.3	35.9	0.92	89.5	89.5	88.6	6.0	2.0	1.7	0.6	2.4	0.0270	82
15.00	AGM2EL 160 M 2b	2945	26.1	48.6	0.92	90.4	90.4	89.7	7.2	2.4	2.1	0.7	2.8	0.0350	93.8
18.50	AGM2EL 160 L 2	2950	32.3	59.9	0.91	90.9	90.8	90.1	7.7	2.6	2.5	0.8	3.0	0.043	110.3
22.00	C.AGM2EL 160 L 2	2950	37.4	71.4	0.92	91.3	91.3	90.8	7.1	2.4	2.3	0.8	2.6	0.05	120
22.00	AGM2EL 180 M 2	2950	38.3	71.2	0.91	91.3	91.3	90.8	8.2	2.6	3.0	1.0	3.5	0.066	122
30	AGM2EL 200 L 2a	2970	52	96	0.91	92.0	92.0	91.2	8.3	2.7	2.7	0.9	3.0	0.13	161.3
37	AGM2EL 200 L 2b	2970	65	119	0.89	92.6	92.6	91.7	8.3	2.7	2.7	0.9	3.0	0.15	191.3

4 pole, 1500 min⁻¹

5.5	AGM2EL 132 S 4	1465	11.2	35.9	0.81	87.9	88.0	87.2	7.0	2.3	2.8	0.9	3.5	0.021	40
7.5	AGM2EL 132 M 4	1465	15.4	48.9	0.79	89.0	89.1	88.1	7.1	2.3	2.7	0.9	3.4	0.026	46.5
11.00	AGM2EL 160 M 4	1465	21.6	71.5	0.82	90.0	90.1	89.3	6.8	2.3	2.4	0.8	3.0	0.0610	90
15.00	AGM2EL 160 L 4	1470	29.4	96.7	0.81	90.6	90.7	89.7	7.4	2.5	2.8	0.9	3.2	0.0820	108
18.50	AGM2EL 180 M 4	1470	34.5	120	0.85	91.3	91.4	90.4	7.7	2.5	3.2	1.0	3.4	0.13	129
22.00	AGM2EL 180 L 4	1470	42.5	143	0.82	91.7	91.7	90.6	8.3	2.7	2.7	1.2	3.8	0.15	140
30.00	AGM2EL 200 L 4	1470	53.5	194.6	0.87	92.5	92.6	92.1	7.8	2.6	2.8	0.9	2.8	0.2270	215

6 pole, 1000 min⁻¹

3.00	AGM2EL 132 S 6	960	7.1	30.3	0.73	83.3	83.2	80.4	4.2	1.4	1.6	0.5	2.2	0.0190	35
4.00	AGM2EL 132 M 6a	960	9.3	40.2		84.6	84.5	81.6	4.7	1.6	2.0	0.7	2.5	0.024	44
5.50	AGM2EL 132 M 6b	960	12.7	54.7	0.72	86.0	86.0	83.1	4.9	1.6	2.2	0.7	2.6	0.032	54.8
7.50	AGM2EL 160 M 6	975	17.9	73.9	0.69	87.2	87.2	84.5	6.3	2.1	2.6	0.9	3.5	0.0760	82
11.00	AGM2EL 160 L 6	970	22.5	108.7	0.80	88.7	88.7	85.7	6.2	2.1	3.0	1.0	3.0	0.109	108
15.00	AGM2EL 180 L 6	965	29	148	0.83	89.7	89.7	86.8	6.5	2.1	2.4	0.8	3.0	0.2	147
18.50	AGM2EL 200 L 6a	980	37.7	180.5	0.78	90.4	90.4	87.7	7.2	2.4	2.3	0.8	3.2	0.2340	167
22.00	AGM2EL 200 L 6b	980	43.4	215.4	0.80	91.1	91.1	88.4	6.7	2.2	2.3	0.8	2.8	0.2830	187

Efficiencies are calculated according to indirect method where the additional load losses are determined from exact measurements at different load points.
 (IEC 60034-2-1 : 2014)

ELIT SERIES - RATINGS AND PERFORMANCE

IE2 3-phase, 400 V, 50 Hz
 Duty type : S1 (continuous)
 Degree of protection : IP 55
 Insulation class : F (155°C)
 Temp. Rise : Class B (80K)

ALUMINIUM HOUSING

Rated output	Type	Full-load data							Starting data				Breakdown torque ratio M_K / M_N	Moment of inertia J	Weight approx. B3
		Speed	Current	Torque	Power Factor	Efficiency η %			Locked-rotor current ratio I_A / I_N		Locked-rotor torque ratio M_A / M_N				
		n	I_N	M_N	Cos ϕ	IEC 60034-2-1:2007			D.O.L.	Y/ Δ	D.O.L.	Y/ Δ			
kW		min ⁻¹	A	Nm		At 4/4	At 3/4	At 1/2						kgm ²	kg

2 pole, 3000 min⁻¹

5.5	GM2EL 132 S 2	2905	9.8	18.1	0.92	87.3	87.3	86.5	6.2	2.1	1.9	0.6	2.5	0.0130	45
7.5	GM2EL 132 M 2	2910	13.6	24.6	0.90	88.5	88.5	87.9	7.2	2.3	3.0	1.0	3.4	0.014	64.5
11.00	GM2EL 160 M 2a	2945	19.3	35.9	0.92	89.5	89.5	88.6	6.0	2.0	1.7	0.6	2.4	0.0270	105
15.00	GM2EL 160 M 2b	2945	26.1	48.6	0.92	90.4	90.4	89.7	7.2	2.4	2.1	0.7	2.8	0.0350	117
18.50	GM2EL 160 L 2	2950	32.3	59.9	0.91	90.9	90.8	90.1	7.7	2.6	2.5	0.8	3.0	0.043	135
22.00	C.GM2EL 160 L 2	2950	37.4	71.4	0.92	91.3	91.3	90.8	7.1	2.4	2.3	0.8	2.6	0.05	145
22.00	GM2EL 180 M 2	2950	38.3	71.2	0.91	91.3	91.3	90.8	8.2	2.6	3.0	1.0	3.5	0.066	158
30	GM2EL 200 L 2a	2970	52	96	0.91	92.0	92.0	91.2	8.3	2.7	2.7	0.9	3.0	0.13	210
37	GM2EL 200 L 2b	2970	65	119	0.89	92.6	92.6	91.7	8.3	2.7	2.7	0.9	3.0	0.15	240

4 pole, 1500 min⁻¹

5.5	GM2EL 132 S 4	1465	11.2	35.9	0.81	87.9	88.0	87.2	7.0	2.3	2.8	0.9	3.5	0.021	53
7.5	GM2EL 132 M 4	1465	15.4	48.9	0.79	89.0	89.1	88.1	7.1	2.3	2.7	0.9	3.4	0.026	61
11.00	GM2EL 160 M 4	1465	21.6	71.5	0.82	90.0	90.1	89.3	6.8	2.3	2.4	0.8	3.0	0.0610	113
15.00	GM2EL 160 L 4	1470	29.4	96.7	0.81	90.6	90.7	89.7	7.4	2.5	2.8	0.9	3.2	0.0820	132
18.50	GM2EL 180 M 4	1470	34.5	120	0.85	91.3	91.4	90.4	7.7	2.5	3.2	1.0	3.4	0.13	165
22.00	GM2EL 180 L 4	1470	42.5	143	0.82	91.7	91.7	90.6	8.3	2.7	2.7	1.2	3.8	0.15	180
30.00	GM2EL 200 L 4	1470	53.5	194.6	0.87	92.5	92.6	92.1	7.8	2.6	2.8	0.9	2.8	0.2270	263

6 pole, 1000 min⁻¹

3.00	GM2EL 132 S 6	960	7.1	30.3	0.73	83.3	83.2	80.4	4.2	1.4	1.6	0.5	2.2	0.0190	50
4.00	GM2EL 132 M 6a	960	9.3	40.2		84.6	84.5	81.6	4.7	1.6	2.0	0.7	2.5	0.024	60
5.50	GM2EL 132 M 6b	960	12.7	54.7	0.72	86.0	86.0	83.1	4.9	1.6	2.2	0.7	2.6	0.032	70
7.50	GM2EL 160 M 6	975	17.9	73.4	0.69	87.2	87.2	84.5	6.3	2.1	2.6	0.9	3.5	0.0760	105
11.00	GM2EL 160 L 6	970	22.5	108.7	0.80	88.7	88.7	85.7	6.2	2.1	3.0	1.0	3.0	0.1090	133
15.00	GM2EL 180 L 6	965	29	148	0.83	89.7	89.7	86.8	6.5	2.1	2.4	0.8	3.0	0.2	186
18.50	GM2EL 200 L 6a	980	37.7	180.5	0.78	90.4	90.4	87.7	7.2	2.4	2.3	0.8	3.2	0.2340	216
22.00	GM2EL 200 L 6b	980	43.4	215.4	0.80	91.1	91.1	88.4	6.7	2.2	2.3	0.8	2.8	0.2830	236

Efficiencies are calculated according to indirect method where the additional load losses are determined from exact measurements at different load points.
 (IEC 60034-2-1 : 2014)

ELIT SERIES - DIMENSIONS

FOOT MOUNTED (B3)

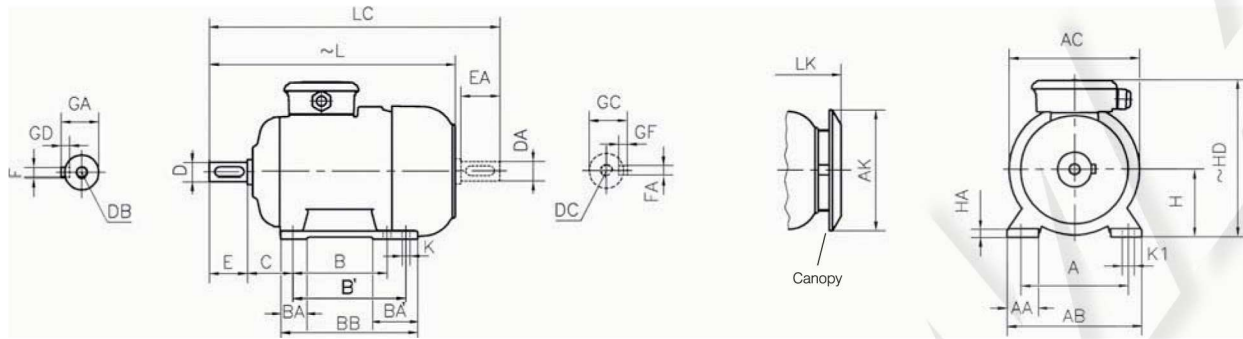

ALUMINIUM HOUSING

Frame size	Number of pole	Dimensions of foot mounted motors for mounting arrangements : B3, B6, B7, B8, B15, V5, V6																					
		H	HD ~	HA	A	AA	AB	ØAC	ØAK	K	B	B'	BA	BA'	BB	L ~	LC	LK ~	C	E EA	DB ¹⁾ DC	Ø D Ø DA	GA GC
132	S	2-4-6-8	132	307	15	216	50	260	262	239	12	140	55	140	483.5	572	520.5	89	80	M12	38	41	10x8
	178											528.5			617	565.5							
160	M	2-4-6-8	160	390	22	254	63	312	315	303	15	210	70	210	629.5	745.5	686.5	108	110	M16	42	45	12x8
	254											674.5		790.5	731.5								
180	M	2-4-6-8	180	430	24	279	74	354	354	303	15	241	75	241	686	802	743	96	110	M16	48	51.5	x14x9
	279											723		839	780								
200	L	2-4-6-8	200	489	26	318	81	398	394	370	19	305	80	305	819	937	875	133	110	M20	55	59	16x10

CAST IRON HOUSING

Frame size	Number of pole	Dimensions of foot mounted motors for mounting arrangements : B3, B6, B7, B8, B15, V5, V6																					
		H	HD ~	HA	A	AA	AB	ØAC	ØAK	K	B	BA	BB	L ~	LC	LK ~	C	E EA	DB ¹⁾ DC	Ø D Ø DA	GA GC	FxGD FAxGF	
132	S	2-4-6-8	132	307	15	216	50	260	262	239	12	140	50	180	486	572	523	89	80	M12	38	41	10x8
	178											218		531	617	568							
160	M	2-4-6-8	160	390	22	254	63	312	315	303	15	210	62.3	260	629.5	745.5	686.5	108	110	M16	42	45	12x8
	254											70	304	674.5	790.5	731.5							
180	M	2-4-6-8	180	430	24	279	74	354	354	303	15	241	60	291	686	802	743	121	110	M16	48	51.5	x14x9
	279											70	329	723	839	780							
200	L	2-4-6-8	200	489	26	318	81	398	394	370	19	305	72.5	355	819	937	875	133	110	M20	55	59	16x10

ELIT SERIES - DIMENSIONS

FLANGE MOUNTED (FORM A-B5)

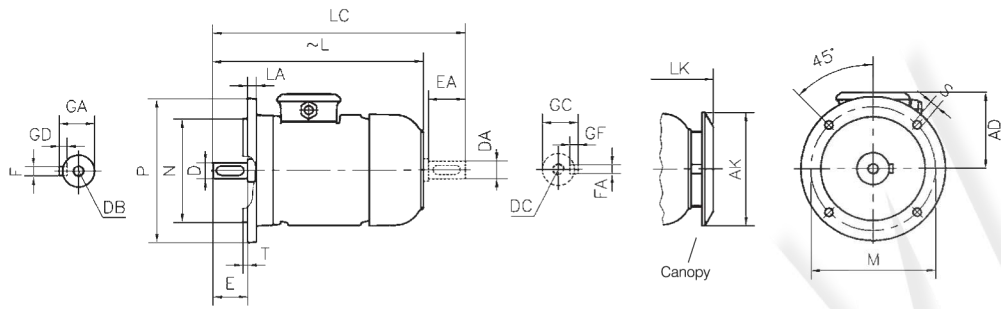

Note: The seating face of the flange lies in the same plane as the shoulder on the shaft

ALUMINIUM HOUSING

Frame size	Dimensions of flanged motors : (D-Flange form A - DIN EN 50 347) mounting arrangements B5, V1, V3																		
	Flange No.	ØM	ØN	ØP	Clearance hole		T	LA	AD ~	ØAK	L ~	LC	LK ~	E EA	DB ¹⁾ DC	ØD ØDA	GA GC	FxGD FxGF	Flange Type
					No.	ØS													
132 S M	FF 265	265	230	300	4	14.5	4	18	194	239	486	572	523	80	M12	38	41	10X8	Aluminium
											531	617	568						
160 M L	FF 300	300	250	350	4	18.5	4	20	231	303	629.5	745.5	686.5	110	M16	42	45	12X8	Aluminium
											674.5	790.5	790.5						
180 M L	FF 300	300	250	350	4	18.5	5	18	251		686	802	743	110	M16	48	51.5	14X9	Aluminium
											723	839	780						
200 L	FF 350	350	300	400	4	18.5	5	20	289		819	937	875	110	M20	55	59	16x10	Aluminium

CAST IRON HOUSING

Frame size	Dimensions of flanged motors : (D-Flange form A - DIN EN 50 347) mounting arrangements B5, V1, V3																		
	Flange No.	ØM	ØN	ØP	Clearance hole		T	LA	AD ~	ØAK	L ~	LC	LK ~	E EA	DB ¹⁾ DC	ØD ØDA	GA GC	FxGD FxGF	Flange Type
					No.	ØS													
132 S M	FF 265	265	230	300	4	14.5	4	18	194	239	486	572	523	80	M12	38	41	10X8	Cast Iron
											531	617	568						
160 M L	FF 300	300	250	350	4	18.5	4	20	231	303	629.5	745.5	686.5	110	M16	42	45	12X8	Cast Iron
											674.5	790.5	790.5						
180 M L	FF 300	300	250	350	4	18.5	5	18	251		686	802	743	110	M16	48	51.5	14X9	Cast Iron
											723	839	780						
200 L	FF 350	350	300	400	4	18.5	5	20	289		819	937	875	110	M20	55	59	16x10	Cast Iron

ELIT SERIES - DIMENSIONS

FOOT AND FLANGE MOUNTED (FORM A-B5)

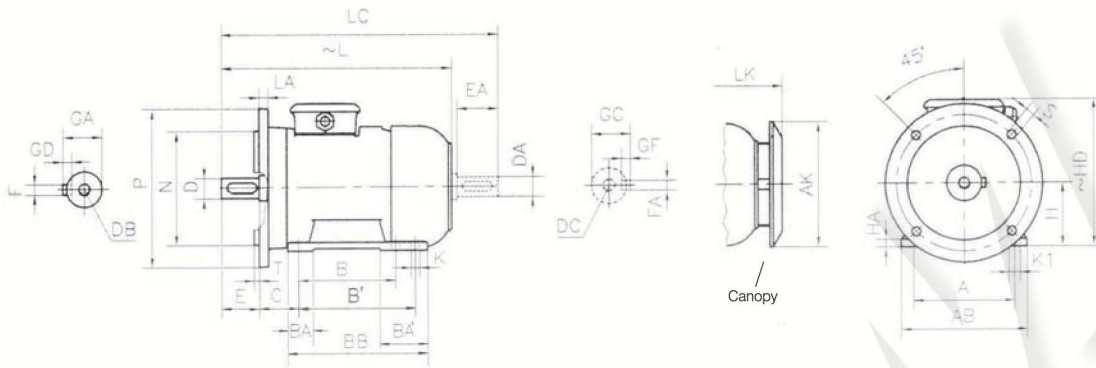

Note: The seating face of the flange lies in the same plane as the shoulder on the shaft

ALUMINIUM HOUSING

Frame size	Dimensions of foot and flange mounted motors : (D-Flange form A-DIN EN 50 347) mounting arrangements B35																																
	H	HD	HA	A	AB	ØAK	K	K1	B	B'	BA	BA'	BB	Flanş	ØM	ØN	ØP	No	ØS	T	LA	L	LC	LK	C	E	EA	DB ¹⁾	ØD	ØDA	GA	GC	FxGD
132 — S — M	132	307	15	216	260	239	12	-	140	-	55	-	180	FF 265	265	230	300	4	14.5	4	18	483.5	572	520.5	89	80	M12	38	41	10X8			
		178							218				218									617	565.5										
160 — M — L	160	390	22	254	312	303	15	-	210	-	70	-	260	FF 300	300	250	350	4	18.5	4	20	629.5	745.5	686.5	108	110	M16	42	45	12X8			
		254							304				304									731.5	731.5										
180 — M — L	180	430	24	279	354	303	15	-	241	-	75	-	291	FF 300	300	250	350	4	18.5	5	18	686	802	743	96	110	M16	48	51.5	14X9			
		279							329				329									780	780										
200 L	200	489	26	318	398	370	19	-	305	-	80	-	365	FF 350	350	300	400	4	18.5	5	20	819	937	875	133	110	M20	55	59	16X10			

CAST IRON HOUSING

Frame size	Dimensions of foot and flange mounted motors : (D-Flange form A-DIN EN 50 347) mounting arrangements B35																																
	H	HD	HA	A	AB	ØAK	K	K1	B	B'	BA	BA'	BB	Flanş	ØM	ØN	ØP	No	ØS	T	LA	L	LC	LK	C	E	EA	DB ¹⁾	ØD	ØDA	GA	GC	FxGD
132 — S — M	132	326	15	216	260	239	12	-	140	-	50	-	180	FF 265	265	230	300	4	14.5	4	18	486	572	523	89	80	M12	38	41	10X8			
		178							218				218									617	568										
160 — M — L	160	390	22	254	312	303	15	-	210	-	62.3	-	260	FF 300	300	250	350	4	18.5	4	20	629.5	745.5	686.5	108	110	M16	42	45	12X8			
		254							70		304		731.5									731.5											
180 — M — L	180	431	24	279	354	303	15	-	241	-	60	-	291	FF 300	300	250	350	4	18.5	5	18	686	802	743	121	110	M16	48	51.5	14X9			
		279							70		329		780									780											
200 L	200	489	26	318	398	370	19	-	305	-	72.5	-	355	FF 350	350	300	400	4	18.5	5	20	819	937	875	133	110	M20	55	59	16X10			

ELIT SERIES - DIMENSIONS

FLANGE MOUNTED (FORM C-B14)

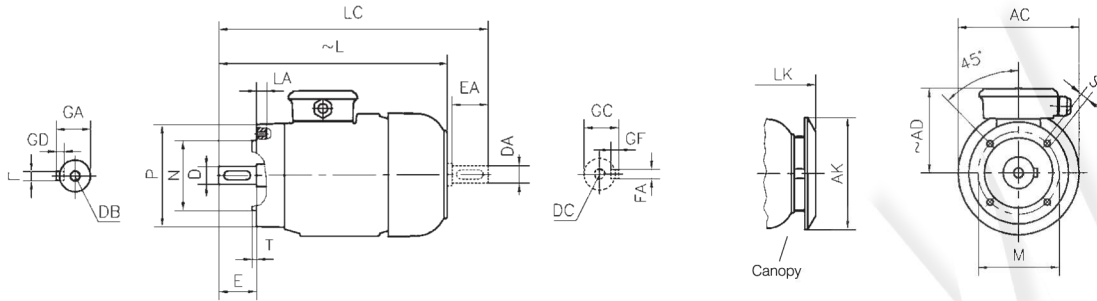

Note: The seating face of the flange lies in the same plane as the shoulder on the shaft

ALUMINIUM HOUSING

Frame size	Dimensions of flanged motors : (C-Face Flange form C - DIN EN 50 347) mounting arrangements B14, V18, V19																		
	Flange No.	ØM	ØN	ØP	S	T	LA ^{*)}	Ø AC	Ø AK	AD	L	LC	LK	E EA	DB ¹⁾ DC	Ø D Ø DA	GA GC	FxGD FxGF	
132	S	FT 165	165	130	250	M10	3.5	19	262	239	194	483.5	572	520.5	80	M12	38	41	10X8
	M										194	528.5	617	565.5					
160	M	FT 215	215	180	250	M12	4	21	315	303	230.5	629.5	745.5	686.5	110	M16	42	45	12X8
	L										230.5	674.5	790.5	731.5					

CAST IRON HOUSING

Frame size	Dimensions of flanged motors : (C-Face Flange form C - DIN EN 50 347) mounting arrangements B14, V18, V19																		
	Flange No.	ØM	ØN	ØP	S	T	LA ^{*)}	Ø AC	Ø AK	AD	L	LC	LK	E EA	DB ¹⁾ DC	Ø D Ø DA	GA GC	FxGD FxGF	
132	S	FT 165	165	130	250	M10	3.5	19	262	239	194	486	572	523	80	M12	38	41	10X8
	M										194	531	617	568					
160	M	FT 215	215	180	250	M12	4	21	315	303	230.5	629.5	745.5	686.5	110	M16	42	45	12X8
	L										230.5	674.5	790.5	731.5					

ELIT SERIES - DIMENSIONS

FOOT AND FLANGE MOUNTED (FORM C-B34)

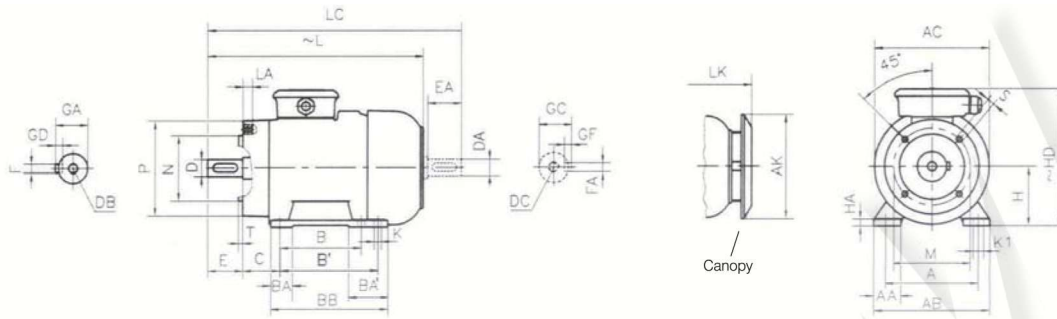

Note: The seating face of the flange lies in the same plane as the shoulder on the shaft

ALUMINIUM HOUSING

Frame size	Dimensions of foot and flange mounted motors : (C-Face Flange form C - DIN EN 50 347) mounting arrangements B34																														
	H	HD	HA	A	AA	AB	ØAC	ØAK	K	K1	B	B'	BA	BA'	BB	Flang No.	ØM	ØN	ØP	S	T	LA ³⁾	L	LC	LK	C	E EA	DB ¹⁾ DC	Ø D Ø DA	GA GC	FxGD FxGF
132	S	132	307	15	216	50	260	262	239	12	140	-	55	-	180	FT 165	165	130	250	M10	3.5	19	483.5	572	520.5	89	80	M12	38	41	10X8
	M	132	307	15	216	50	260	262	239	12	178	-	55	-	218	FT 165	165	130	250	M10	3.5	19	528.5	617	565.5	89	80	M12	38	41	10X8
160	M	160	390	22	254	63	312	315	303	15	210	-	70	-	260	FT 215	215	180	250	M12	4	21	629.5	745.5	686.5	108	110	M16	42	45	12X8
	L	160	390	22	254	63	312	315	303	15	254	-	70	-	304	FT 215	215	180	250	M12	4	21	674.5	790.5	731.5	108	110	M16	42	45	12X8

CAST IRON HOUSING

Frame size	Dimensions of foot and flange mounted motors : (C-Face Flange form C - DIN EN 50 347) mounting arrangements B34																														
	H	HD	HA	A	AA	AB	ØAC	ØAK	K	K1	B	B'	BA	BA'	BB	Flang No.	ØM	ØN	ØP	S	T	LA ³⁾	L	LC	LK	C	E EA	DB ¹⁾ DC	Ø D Ø DA	GA GC	FxGD FxGF
132	S	132	326	15	216	50	260	262	239	12	140	-	55	-	180	FT 165	165	130	250	M10	3.5	19	486	572	523	89	80	M12	38	41	10X8
	M	132	326	15	216	50	260	262	239	12	178	-	55	-	218	FT 165	165	130	250	M10	3.5	19	531	617	568	89	80	M12	38	41	10X8
160	M	160	390	22	254	63	312	315	303	15	210	-	62.3	-	260	FT 215	215	180	250	M12	4	21	629.5	745.5	686.5	108	110	M16	42	45	12X8
	L	160	390	22	254	60	312	315	303	15	254	-	70	-	304	FT 215	215	180	250	M12	4	21	674.5	790.5	731.5	108	110	M16	42	45	12X8

ELIT SERIES SPARES

The spare-parts are fully interchangeable as they are designed and manufactured to fine limits of their dimensional tolerances. Please state motor type, serial number, type of construction-mounting arrangement and part number with full description when ordering spare parts.

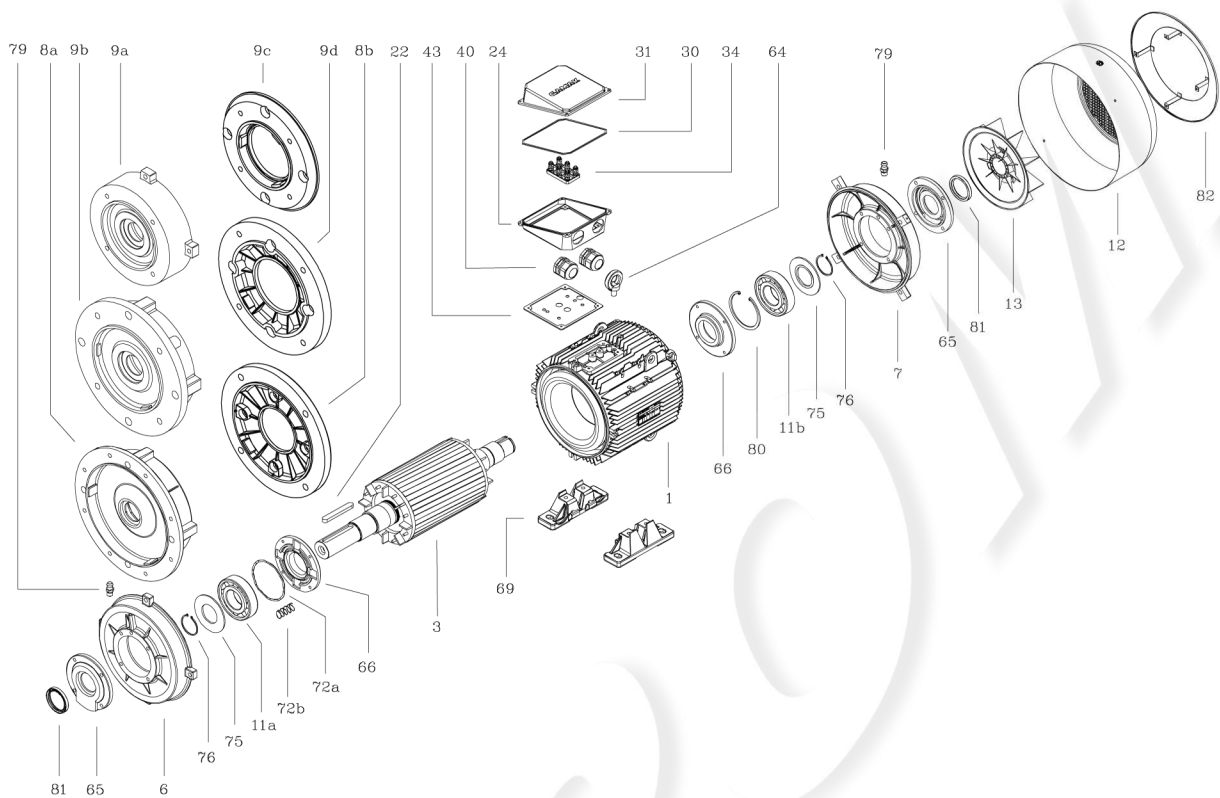

Part No.	Description
1 -	Stator complete with winding, varnished and fitted in the frame
3 -	Rotor complete with shaft, finish machined and balanced (Excluding keys)
6 -	End shield Drive-end B3 mounting
7 -	End shield Non Drive-end
8a -	Flange (Form A)
8b -	Attachable Flange (Form A) - 132 type only
9a -	Flange (Form C)
9b -	Flange (Form C - Large)
9c -	Attachable Flange (Form C) - 132 type only
9d -	Attachable Flange (Form C - Large) - 132 type only
11a -	Bearing Drive-end (Ball or Roller)
11b -	Ball-bearing Non Drive-end
12 -	Fan cover
13 -	Fan
22 -	Shaft key
24 -	Terminal-box
30 -	Terminal-box to lid gasket
31 -	Terminal-box lid
34 -	Terminal board complete with terminal links, nuts and washers
40 -	Cable-gland
43 -	Terminal-box to frame gasket
64 -	Eye bolt
65 -	External bearing cap (motors with greasing nipples)
66 -	Internal bearing cap (motors with greasing nipples)
69 -	Removable feet - Aluminium housings only
72a -	Corrugated disc spring for preloading ball-bearing
72b -	Helical compression spring
75 -	Grease retaining disc (motors with greasing nipples)
76 -	External circlip for retaining ball-bearing and grease retaining disc on the shaft
79 -	Greasing nipple (132 to 200 optional)
80 -	Internal circlip for retaining ball-bearing at N.DE
81 -	V-Ring
82 -	Canopy