

Part number:

**HYDROMA**

HYDRAULICKÉ SYSTÉMY

**HIDROMA  
SISTEMS**

UKŁADY HYDRAULICZNE

**HYDROMA**

ГИДРАВЛИЧЕСКИЕ СИСТЕМЫ



**MATERIALS**

BODY	9 S MN Pb 23 - UNI 5105
NEEDLE	1 C 40 - UNI 8373
O R	NITRILE
ANTIEXTRUSION RINGS	PTFE
CHECK VALVES	38 Ni CR Mo 4 UNI - EN 10083
SPRING	C72 UNI 3545
THREADED FOUND	35 S MN Pb 10 - UNI 5105
KNOB	GD AL Si 12 - UNI 5706
KNOB (MP)	ABS

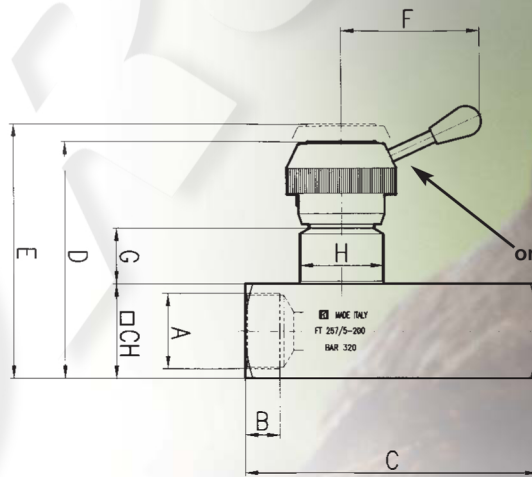
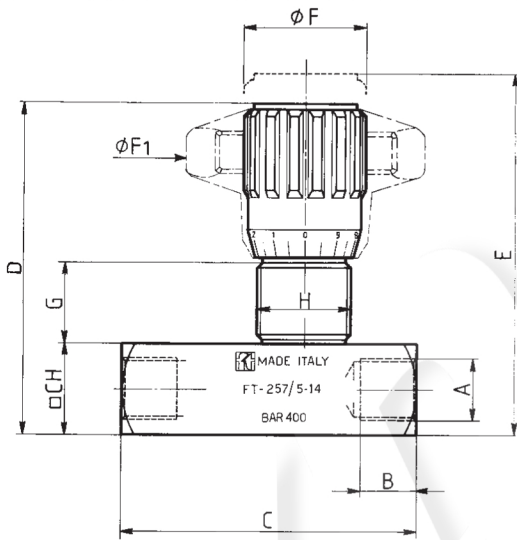

**DIMENSIONS**

TYPE	A UNI 338	B	C	D	E	Ø F	Ø F1	G	H	CH	WEIGHT KG
18	1/8" G	8,5	50	59	64	22	40	13,5	M17x1	16	0,130
14	1/4" G	12,5	66	71	78	27	50	17	M20x1	20	0,250
38	3/8" G	12,5	79	84	93	33	70	19,5	M25x1,5	25	0,500
12	1/2" G	15,5	94,5	97	107	38	80	21	M30x1,5	30	0,750
34	3/4" G	17	115	120,5	132,5	47	100	26,5	M40x1,5	40	1,600
100	1" G	20	138,5	151,5	167,5	58	120	35	M50x1,5	50	3,050
114	1 1/4" G	22	157	156,5	172,5	58	120	35	M50x1,5	55	3,750
112	1 1/2" G	24	190	167	181	58	120	35	M55x2	65	5,760
200	2" G	27	228	188	202	108	-	44	M65x2	75	10,000



## IN LINE SINGLE-ACTING CONTROL VALVES

Their function is to control and, if necessary, to shut-off the flow in one direction, allowing a free return flow in the opposite direction. Appreciated for their aesthetic characteristics, they are a reliable solution.

The suitable dimensioning has made possible to obtain, in a little space, a great mechanic resistance of the components. The spring in high-resistance material is housed in such a way that it does not close as a pack during the opening of the single-acting conical valve poppet.

Like all the valves of the series FT 257 they ensure:

- metallic seal;
- flow linearity at the opening;
- accurate control for a wide range of flow rate, thanks to the double reference system
- wide range of the flow rate control;
- impossibility for the needle to leave its seat even in the max. opening position;
- stable positioning thanks to a dowel inside the knob;
- quickness in the assembling of the panel (the ring nuts (G) are supplied on request).

The check valve is calibrated at 0,5 bar.

### On request

- Versions AISI 316 code FT 2257/5
- Viton seals (V)
- NPT threads
- Equipped with ring nuts (G)
- Knob in ABS (mp)



### EXAMPLE FOR ORDERING

	CODE	TYPE	PANNEL RING NUT	VITON SEAL	KNOB IN PLASTIC
STEEL	FT 257/5	18	G	V	MP
STAINLESS STEEL	FT 2257/5	34	G	-	MP

### TECHNICAL DATA

TYPE	FLOW SECTION CM <sup>2</sup>	WORKING PRESSURE BAR	MIN. BURSTING PRESSURE BAR	WORKING TEMPERATURE	FILTRATION GRADE μM
18	0,12	400	1600	-20°/+100°	25
14	0,19	400	1600	-20°/+100°	25
38	0,39	400	1600	-20°/+100°	25
12	0,68	400	1600	-20°/+100°	25
34	1,13	400	1600	-20°/+100°	25
100	2,09	320	1300	-20°/+100°	25
114	2,09	320	1300	-20°/+100°	25
112	3,14	320	1300	-20°/+100°	25
200	4,91	320	1300	-20°/+100°	25

FT 257/5

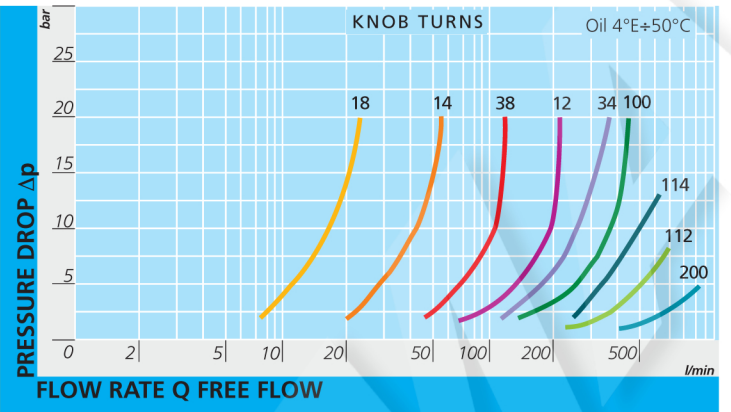

FT 257/5-18

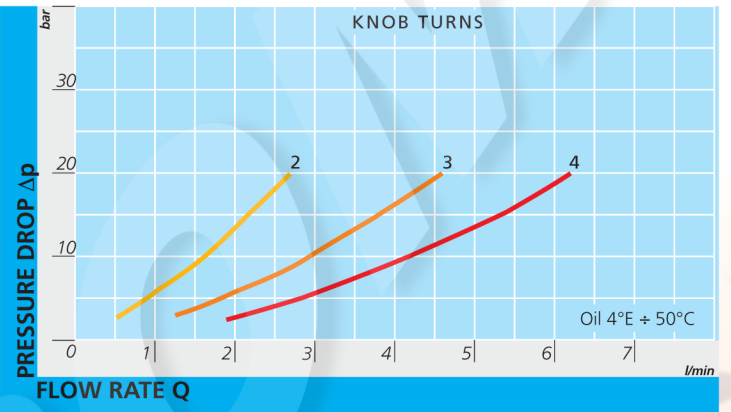

FT 257/5-14

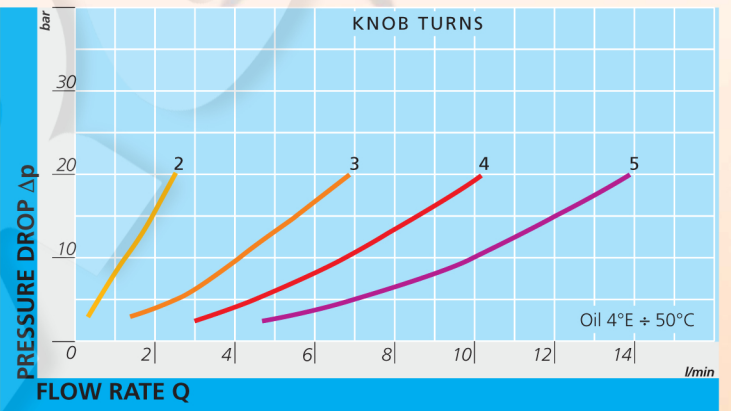

FT 257/5 - 38

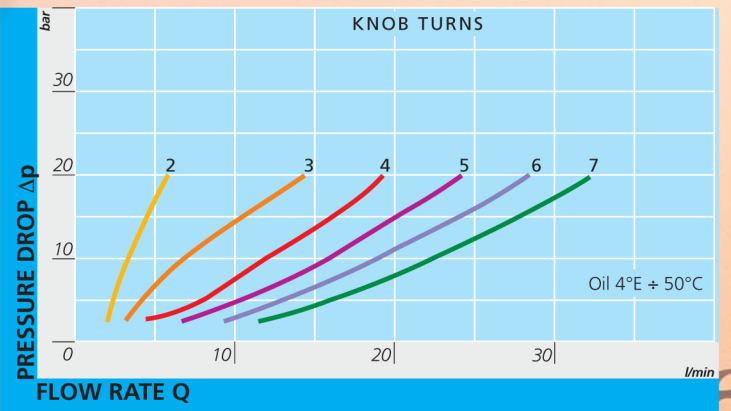

FT 257/5 - 12

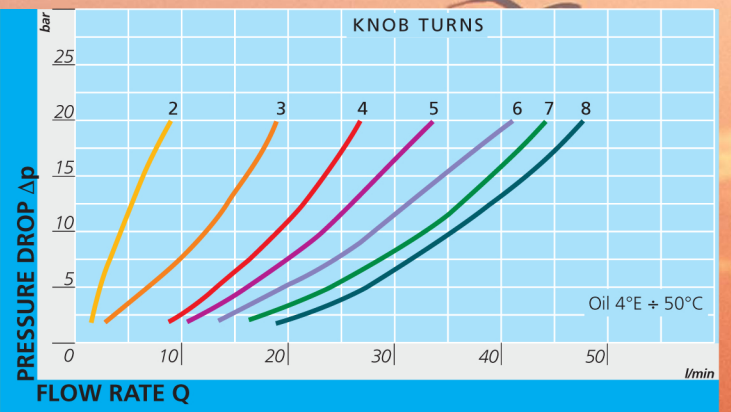



# FLOW RATE CURVES

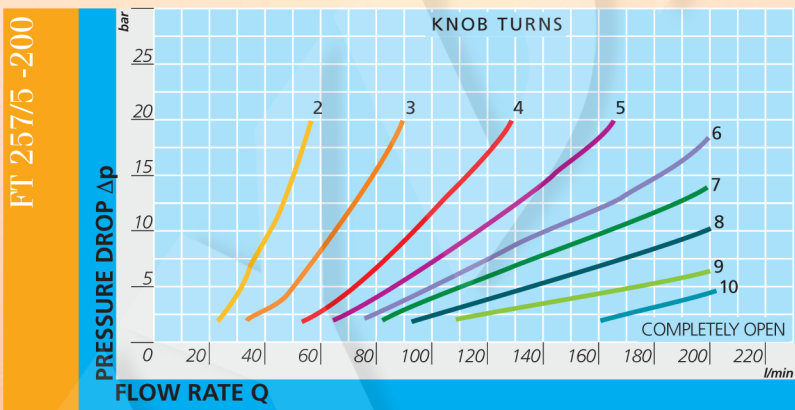
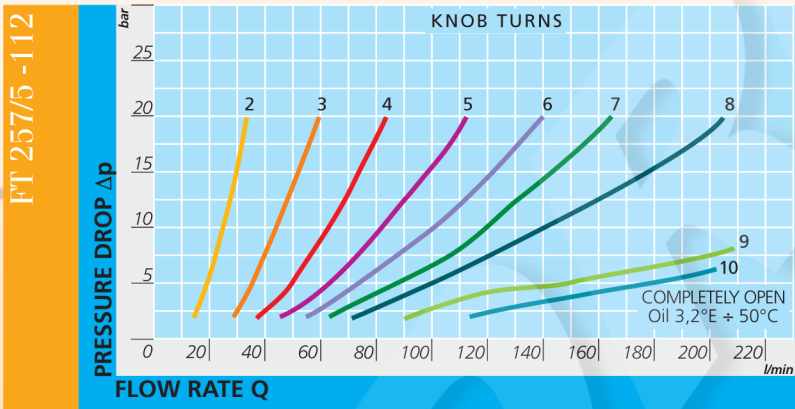
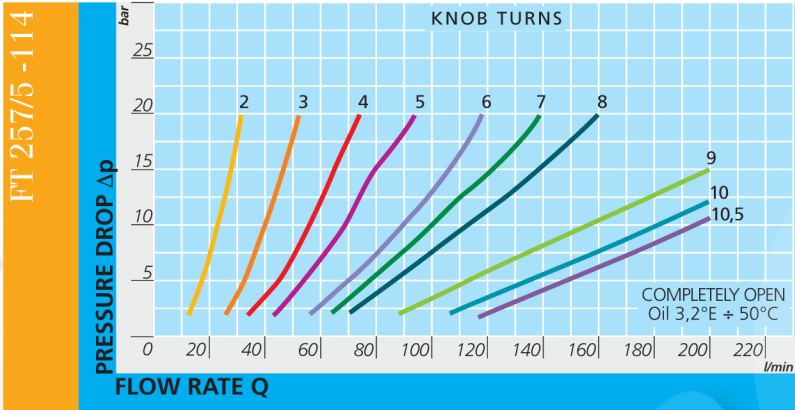
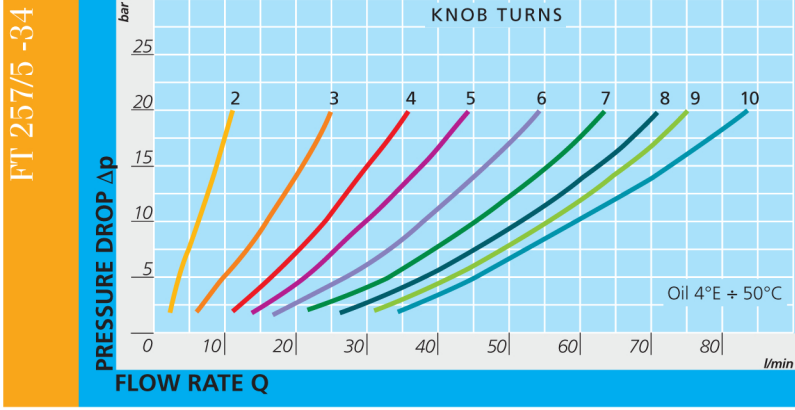



SERIE  
FT 257  
FT 258

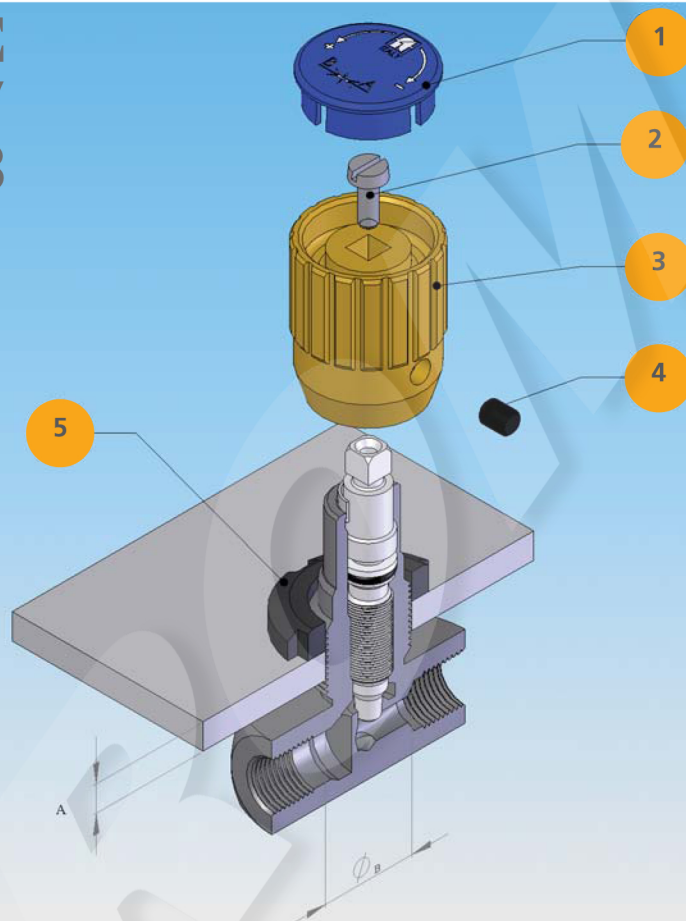

# PANEL MOUNTING INSTRUCTION

## PANEL MOUNTING

1°	UNSCREW LOCK SCREW (4)
2°	REMOVE COVER PLATE (1)
3°	UNSCREW SCREW (2)
4°	PULL OFF HANDLE (3)
5°	INSERT RING NUT (5), ON REQUEST IT IS SUPPLIED WITH THE VALVE

TYPE VALVE	PANEL THICKNESS A MAX	BORE FOR PANEL MOUNTING $\varnothing B$
18	6	18
14	8	21
38	10	26
12	10	31
34	10	41
100	10	51
114	10	51
112	12	56
200	12	66